

SR NO	PART NUMBER	DESCRIPTION	TAP (T) INCH
1	ENO34	EYE NUT OVAL 3/4" 22K LBS	0.770-10 UNC
2	ENO58	EYE NUT OVAL 5/8" 14K LBS	0.645-11 UNC

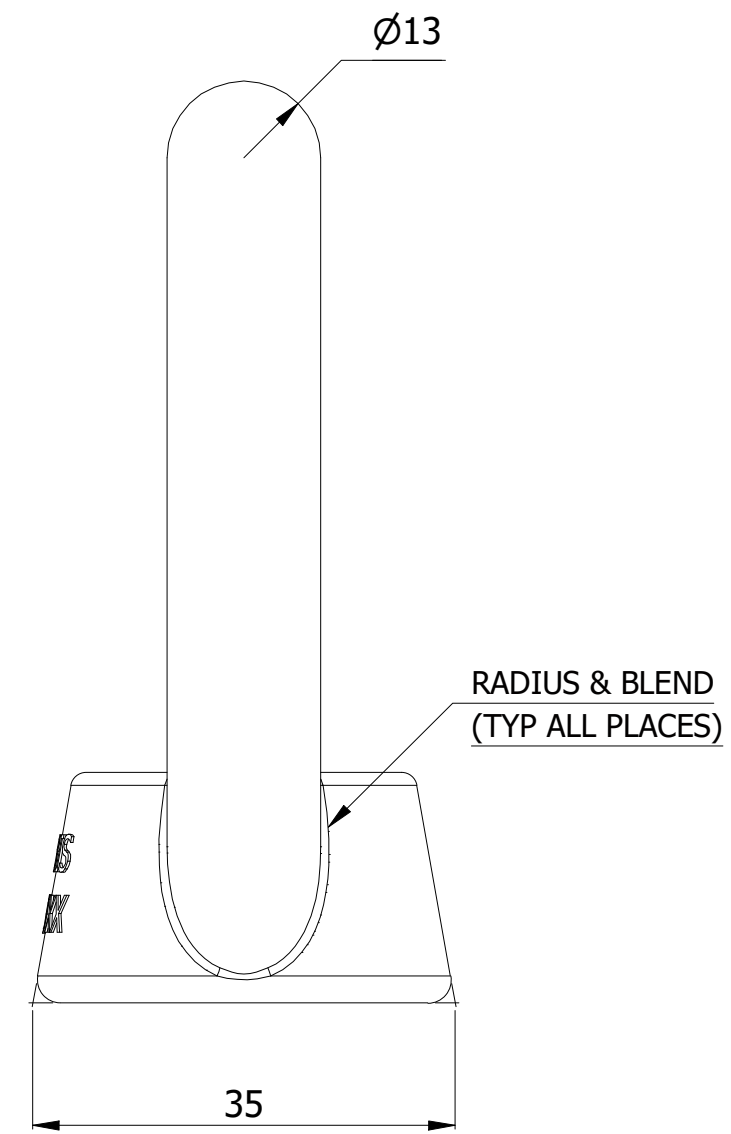
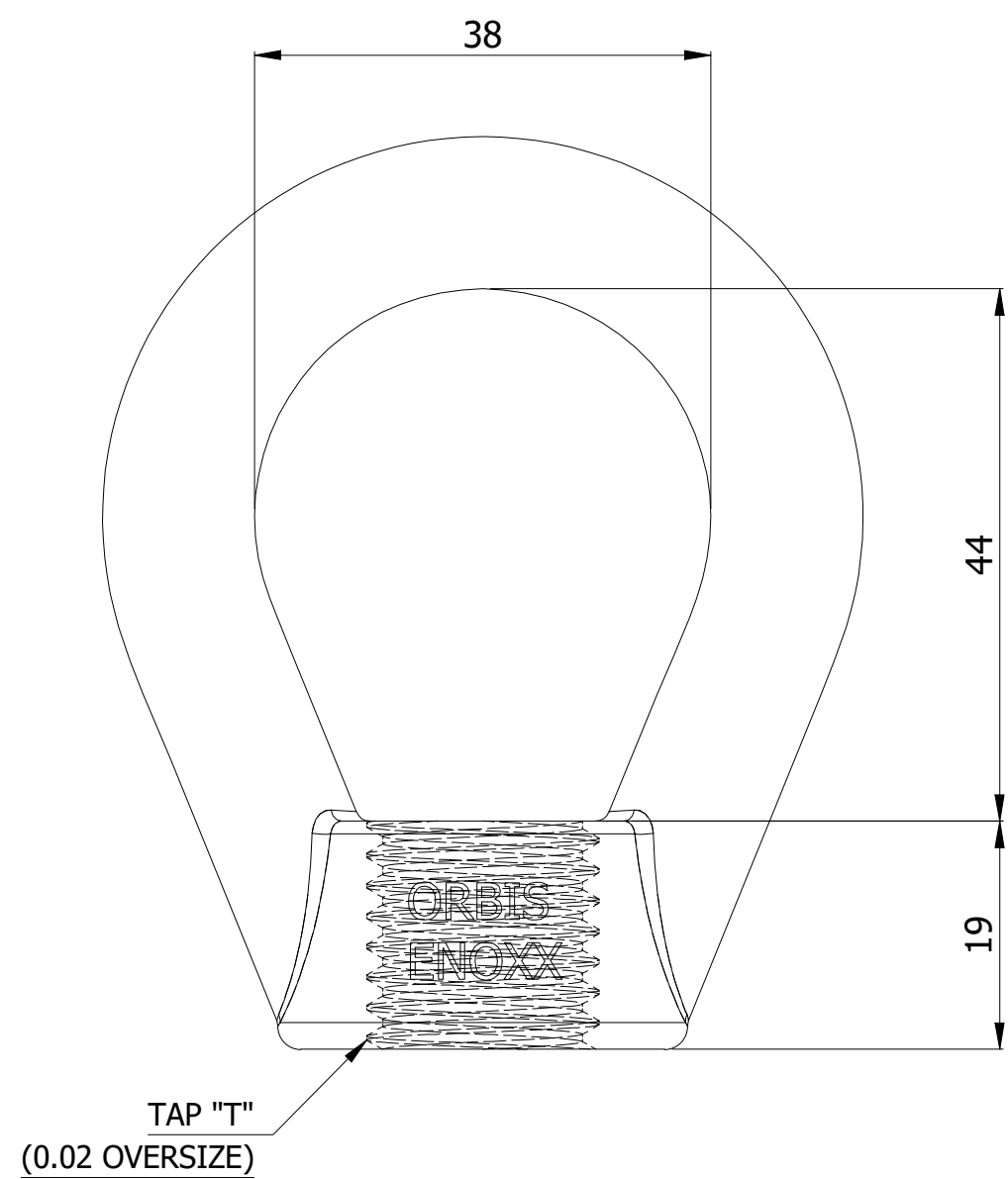

- NOTES:-
1. MATERIAL: STEEL ANSI C135.1
 2. GALVANIZED AS PER ASTM A153
 3. ALL DIMENSIONS ARE IN MM UNLESS OTHERWISE SPECIFIED
 4. TOLERANCE: ±1/16"

THIS DRAWING CONTAINS CONFIDENTIAL INFORMATION AND IS THE EXCLUSIVE PROPERTY OF ORBIS MANUFACTURING	ORBIS			DRAWING NUMBER	
				ENOXX	
				DESCRIPTION	
				EYE NUT OVAL	
DRAWN	MSM	DATE	28-07-2022		
APPROVED	DMM	DATE	04-08-2022		
REVISION	-				