

1.021" - 8 UNC - 2B

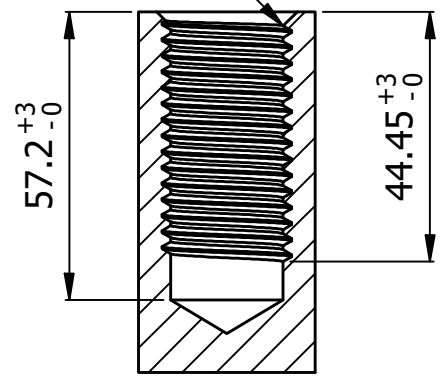

SECTION A-A

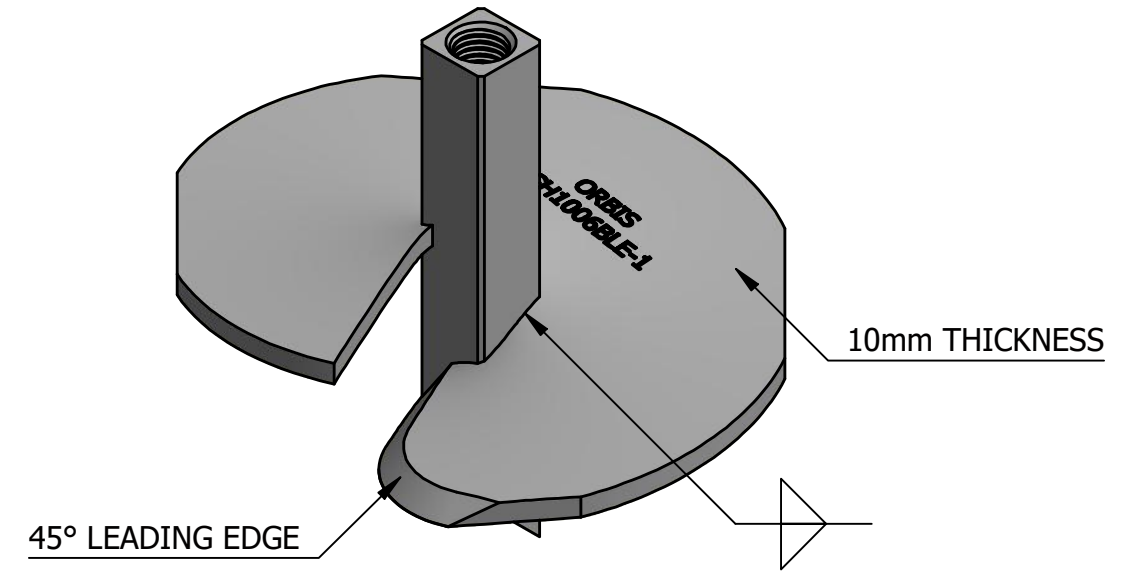
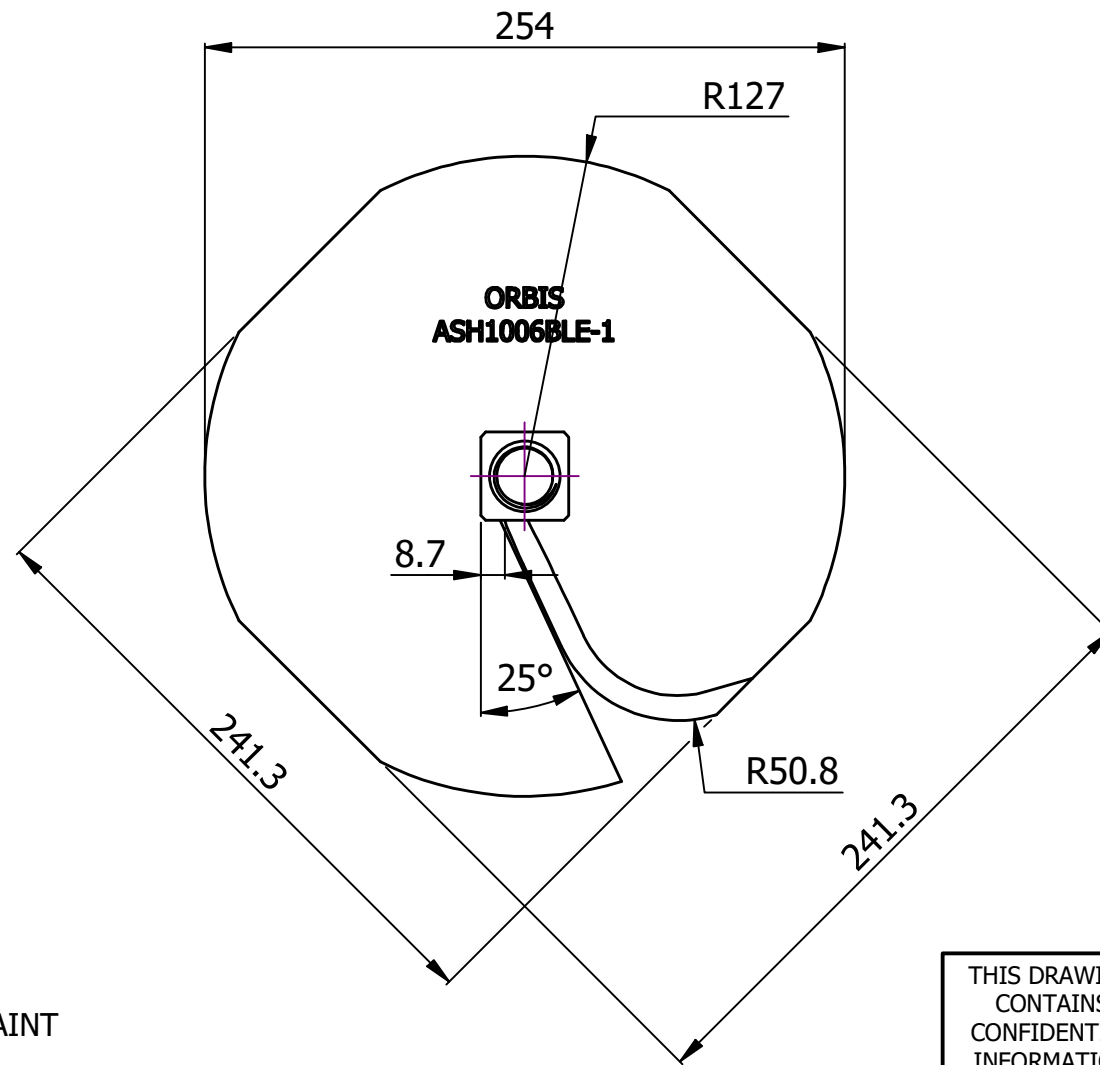
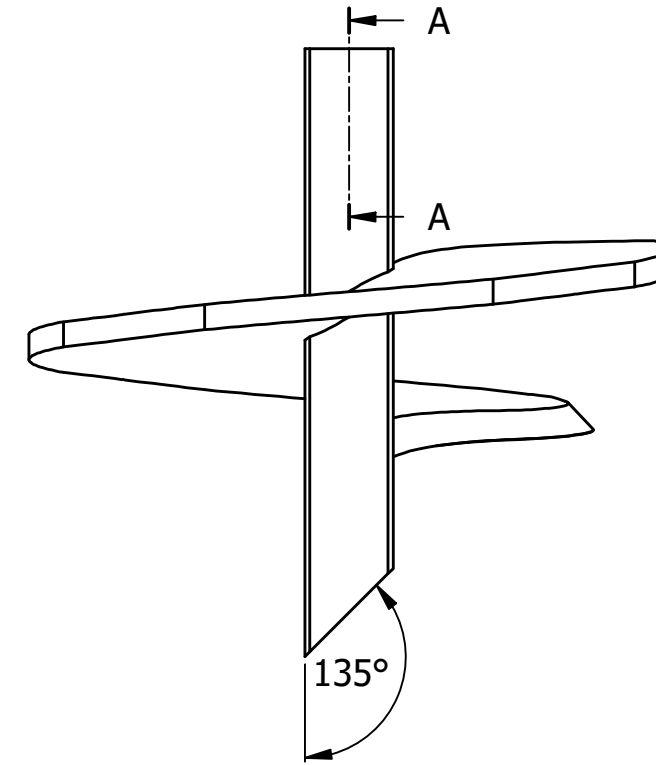
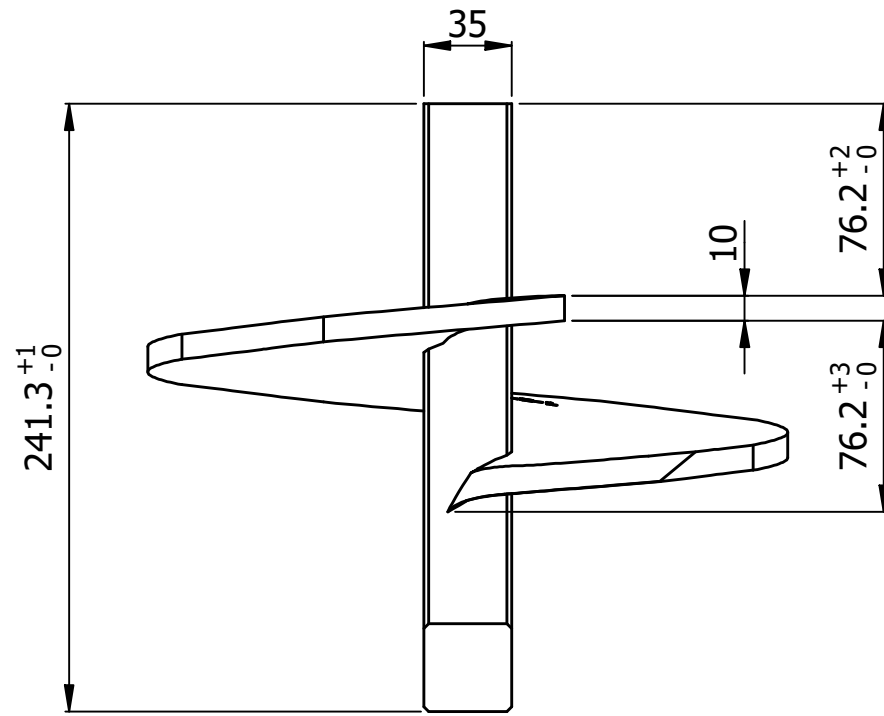

- NOTES:
 1.FINISH: CORROSION-RESISTANT GREY PAINT
 2.TORQUE RATING: 6000 FT-LBS
 3.ALL DIMENSIONS ARE IN MM UNLESS SPECIFIED

THIS DRAWING CONTAINS CONFIDENTIAL INFORMATION AND IS THE EXCLUSIVE PROPERTY OF ORBIS MANUFACTURING

ORBIS

DRAWN	MSM	DATE	20-07-2022
APPROVED	DMM	DATE	25-07-2022
REVISION	-		

DRAWING NUMBER

ASH1006BLE-1

DESCRIPTION

ANCHOR 10" 6000 FT LBS SOLID HUB 1-3/8" SQ OD 1" THREAD BEVELED LEADING EDGE