

**SECTION A-A**

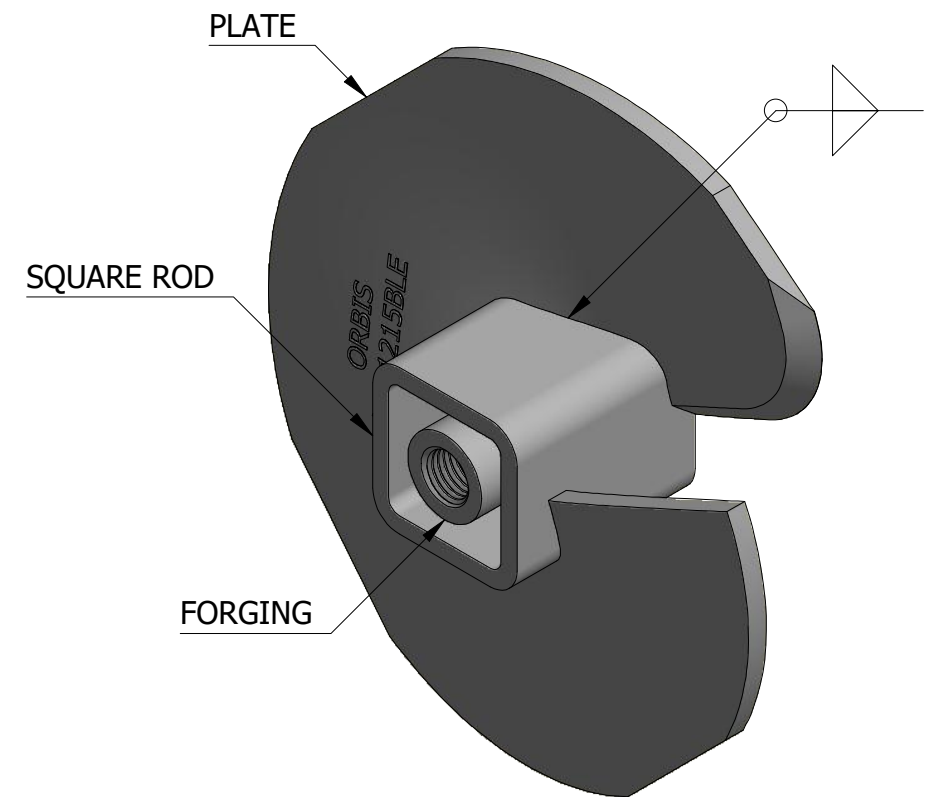

**NOTES:**

1. FINISH: CORROSION-RESISTANT GREY PAINT.
2. TORQUE RATING: 15,000 FT-LBS.
3. ALL DIMENSIONS ARE IN MM UNLESS SPECIFIED.

THIS DRAWING  
CONTAINS  
CONFIDENTIAL  
INFORMATION  
AND IS THE  
EXCLUSIVE  
PROPERTY OF  
ORBIS  
MANUFACTURING



DRAWN	MSM	DATE	18-11-2022
APPROVED	DMM	DATE	26-11-2022
REVISION	-		

**DRAWING NUMBER**

ASD1215BLE

**DESCRIPTION**

ANCHOR 12" 15,000 FT LBS SOCKET DRIVE  
2-1/2" SQ ID 1" THREAD BEVELED  
LEADING EDGE