

**SECTION A-A**

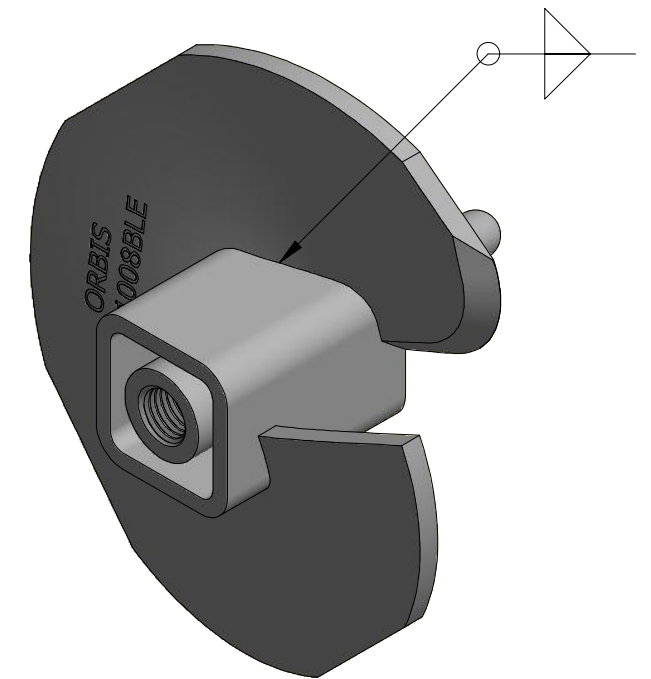

**NOTES:**

1. FINISH: CORROSION-RESISTANT GREY PAINT
2. TORQUE RATING: 8,000 FT-LBS
3. ALL DIMENSIONS ARE IN MM UNLESS SPECIFIED.

THIS DRAWING CONTAINS CONFIDENTIAL INFORMATION AND IS THE EXCLUSIVE PROPERTY OF ORBIS MANUFACTURING



DRAWN	MSM	DATE	03-08-2022
APPROVED	DMM	DATE	08-08-2022
REVISION	-		

**DRAWING NUMBER**

ASD1008BLE

**DESCRIPTION**

ANCHOR 10" 8,000 FT LBS 2-1/4" SQ ID SOCKET DRIVE 1" THREAD BEVELED LEADING EDGE