

VIEW A

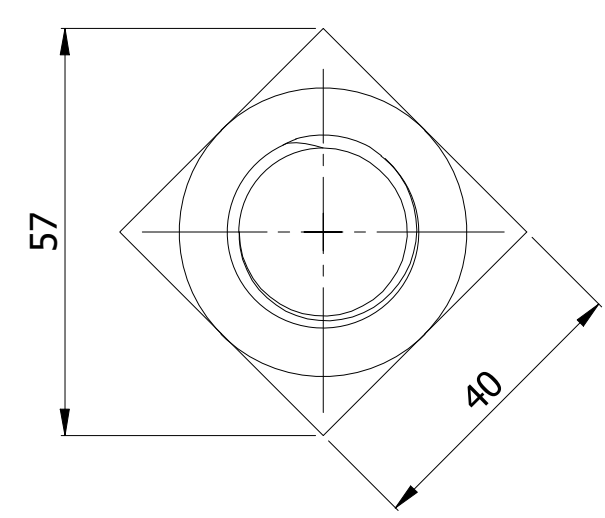

- NOTES:
1. FINISH: HOT DIP GALVANIZED PER ASTM A153
 2. ULTIMATE STRENGTH 161 KN (36,000 LBS)
 3. ASSEMBLED WITH A HEAVY SQUARE NUT
 4. ALL DIMENSIONS IN MM UNLESS SPECIFIED

THIS DRAWING CONTAINS CONFIDENTIAL INFORMATION AND IS THE EXCLUSIVE PROPERTY OF ORBIS MANUFACTURING	ORBIS				DRAWING NUMBER		
					AR108TE		
					DESCRIPTION		
					ANCHOR ROD 8' TRIPLE EYE THIMBLE ROD AND THREAD 1"		
DRAWN	MSM	DATE	08-08-2022	DRAWN	MSM	DATE	08-08-2022
APPROVED	DMM	DATE	15-08-2022	APPROVED	DMM	DATE	15-08-2022
REVISION	DMM	5	08-2022	REVISION	DMM	5	08-2022