

SR NO	PART NUMBER	DESCRIPTION	LENGTH "L"	T LENGTH "T"	THREAD	UTS
1	AR108SE	ANCHOR ROD 8' SINGLE EYE THIMBLE ROD & THREAD 1"	2438	95	1"-8 UNC -2A	36,000 LBS
2	AR110SE	ANCHOR ROD 10' SINGLE EYE THIMBLE ROD & THREAD 1"	3048	95	1"-8 UNC -2A	36,000 LBS

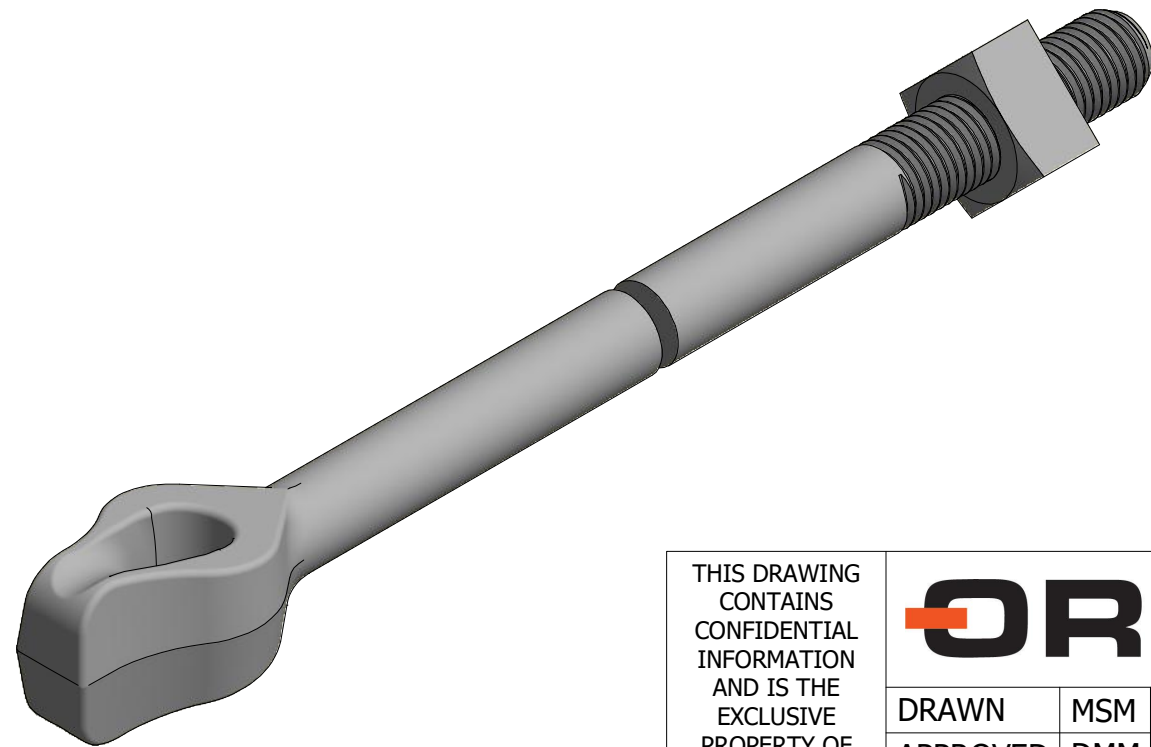
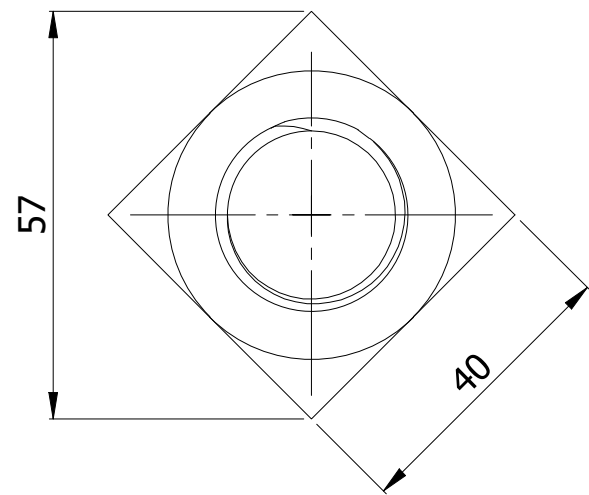
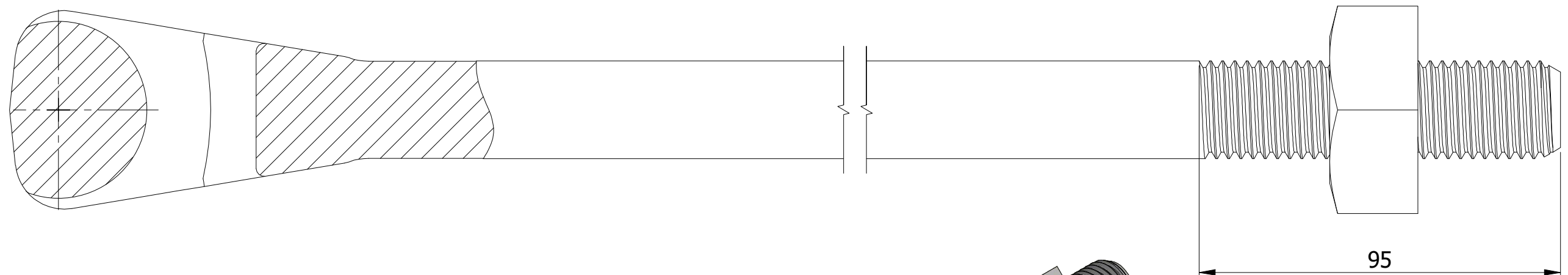
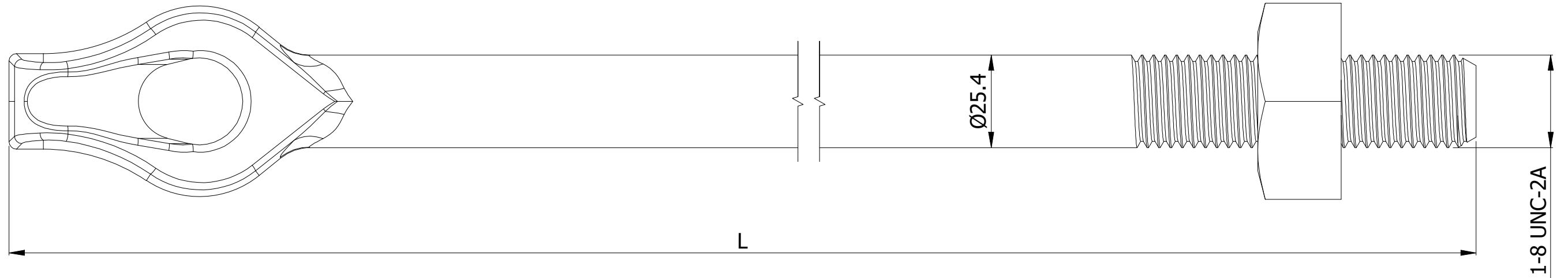

NOTES:

1. HOT DIP GALVANIZED AS PER ASTM A-153
2. ULTIMATE STRENGTH 161 KN (36,000LBS)
3. ASSEMBLED WITH A HEAVY SQUARE NUT
4. ALL DIMENSIONS ARE IN MM UNLESS SPECIFIED

THIS DRAWING
CONTAINS
CONFIDENTIAL
INFORMATION
AND IS THE
EXCLUSIVE
PROPERTY OF
ORBIS
MANUFACTURING



DRAWN	MSM	DATE	08-12-2022
APPROVED	DMM	DATE	15-12-2022
REVISION	-		

DRAWING NUMBER

AR1XXSE

DESCRIPTION

ANCHOR ROD L' SINGLE EYE THIMBLE
ROD AND THREAD 1"